

SPECIFICATION

Customer :

Customer's Model No. :

Model No. : SG100 Series

Date :

Sample Serial No. :

Spec. Version & Revision Date: V1.3 2006.03.27

Received/Approved by



Revision History

Version	Date	Context
1.0	2004.09.21	Golden release
1.1	2005.09.12	
1.2	2005.11.10	Update Current Draw
1.3	2006.03.27	



TABLE OF CONTENTS

A. General Description	4
B. Physical Characteristics.....	5
C. Electrical Characteristics.....	6
D. Performance.....	7
E. Environmental.....	8
F. Readable Symbologies.....	8
G. Pin Assignment.....	9
H. Scan Map.....	11
I. Reliability.....	11
J. Part Number.....	12



A. General Description

This compact hand-held CCD scanner features a comfortable holding especially for female operators. Thanks to the new optical designs, this SG100 supports up to 8 inches scanning depth but more affordable. Wide scanning angles and high scanning speed, quick-release cable design, plus the unique software configuration and ISP function, makes this SG100 a best choice for economic middle to long range CCD scanner in the industry.



B. Physical Characteristics

Weight	
Body weight	Approx. 3.79 oz (118 g)
Material	
	ABS
Connector	
	RJ 45C 10Pins
Dimension	
	140 mm X 71 mm X 90 mm

(a) Cable drawing _ KB Interface

Unit : mm

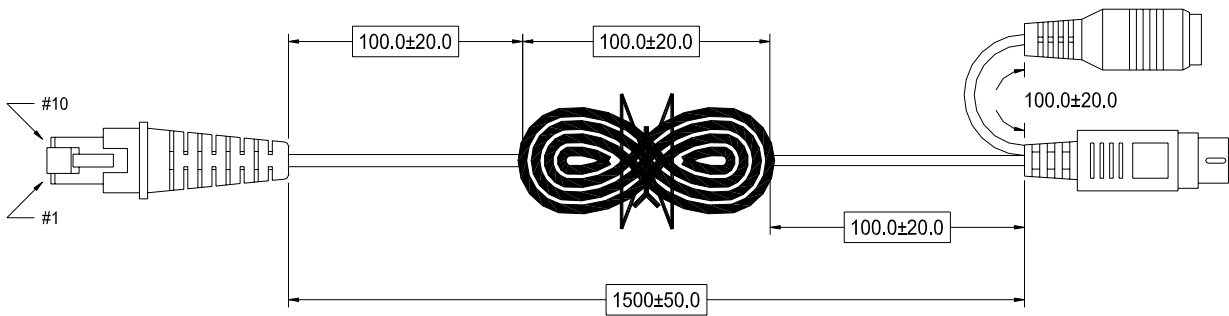

(b) Mechanical drawing

Unit : mm

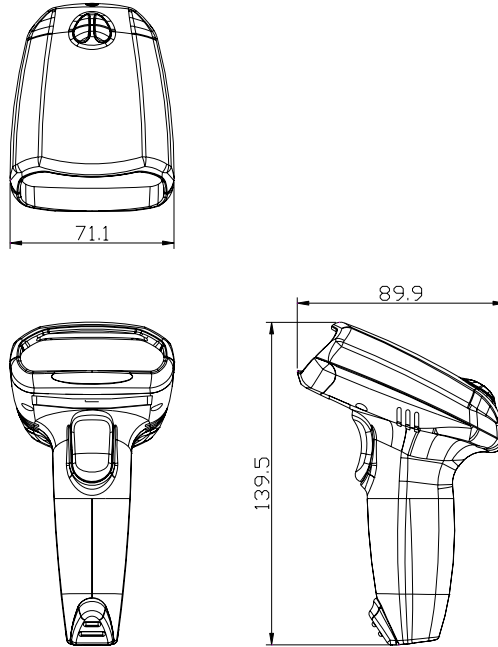

C. Electrical Characteristics

Interface	RS232	RS232 TTL	KB	USB
Supply Voltage	DC +5V ±5%			
Output Voltage (Typ.)	±9V	+5V±5%	+5V±5%	+5V±5%
Output low Voltage (Max.)	-	0.4V	0.4V	0.4V
Current Draw	±10%			
Power On (Typ.)	160 mA	150 mA	150 mA	155 mA
Stand by (Typ.)	50 mA	40 mA	40 mA	45 mA
Operation (Typ.)	130 mA	125 mA	125 mA	130 mA



D. Performance

Light Source	RED 660±10 nm
Sensor	Linear CCD Sensor
Processor Type	8051 compatible
Operating Freq.	29.4912 MHz
Scan Rate	135 scans/sec ± 10%
Reading Distance	200mm(Contact Type)
Width of Field	80 mm
Print Contrast Ratio	PCS 0.3@0.127mm
Resolution	0.1mm @ PCS 0.9
Reading Angle	<i>Test Conditions:Code 39, 10mil, PCS 0.9</i>
Forward&Backward	±60 Degree
Left & Right	±30 Degree
Dead Zone	±5 Degree
Ambient Light	
Fluorescent lamp	5000Lux Max.
Direct sun light	3000Lux Max.

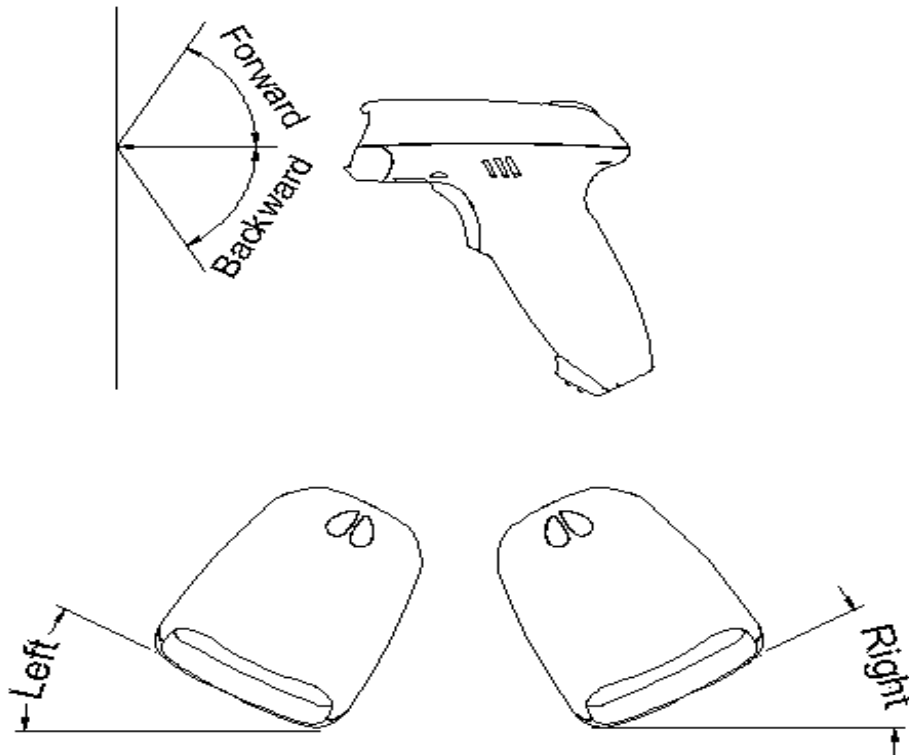

E. Environmental

Operating Temperature	0 °C to 50 °C (32 °F to 122 °F)
Storage Temperature	-20 °C to 70 °C (-4 °F to 158 °F)
Relative Humidity	20% to 95% (Non-condensing)

F. Readable Symbologies

	Readable	Default Enable
All UPC/EAN/JAN	V	V
EAN128 Code	V	V
Code 39	V	V
Code 39 Full ASCII	V	
Code32 / Italian Pharmacy	V	
Code 128	V	V
CODABAR/NW7	V	V
Interleave 25	V	V
Industrial 25	V	
Matrix 25	V	
MSI/PLESSEY	V	
Telepen	V	
Code 93	V	
Code 11	V	
China Postage	V	



G. Pin Assignment

(a) Keyboard Interface

DIN 5 MALE

Pin No.	Function
1	HOST CLK
2	HOST DATA
4	GND
5	Vcc(+5V)

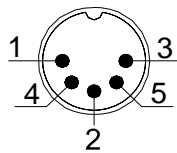

DIN 5 FEMALE

Pin No.	Function
1	KB CLK
2	KB DATA
4	GND
5	Vcc(+5V)

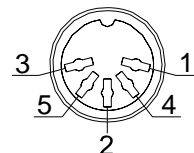

MiniDIN 6 MALE

Pin No.	Function
1	HOST DATA
3	GND
4	Vcc(+5V)
5	HOST CLK

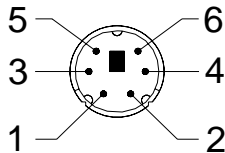

MiniDIN 6 FEMALE

Pin No.	Function
1	KB DATA
3	GND
4	Vcc(+5V)
5	KB CLK

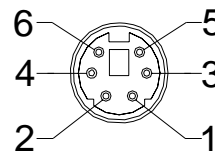

(b) RS-232 Interface

DB 9 Female

Pin No.	Function
2	TXD
3	RXD
5	GND
7	CTS
8	RTS
9	Vcc/+5V
Power Lead	Vcc/+5V

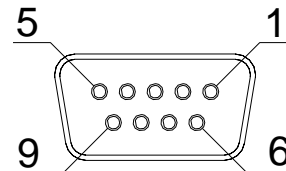

c) WAND Emulation Interface

DB 9 Female

Pin No.	Function
2	DATA
7	GND
9	Vcc

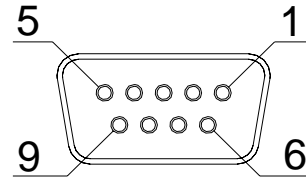

(d) USB Interface

USB A Type Male

Pin No.	Function
1	Vcc
2	D-
3	D+
4	GND

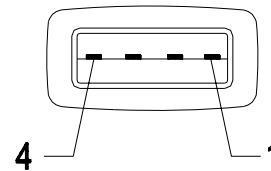

Decoder Data Output

Pin No.	Function
1	RTS
2	HOST DATA
3	GND
4	HOST CLK
5	Vcc (+5V)
6	KB CLK
7	TXD
8	KB DATA
9	RXD
10	CTS

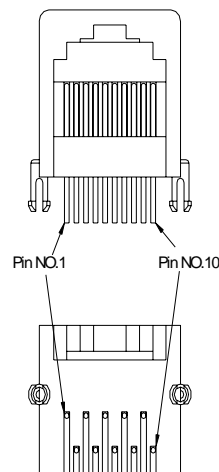

H. Scan Map

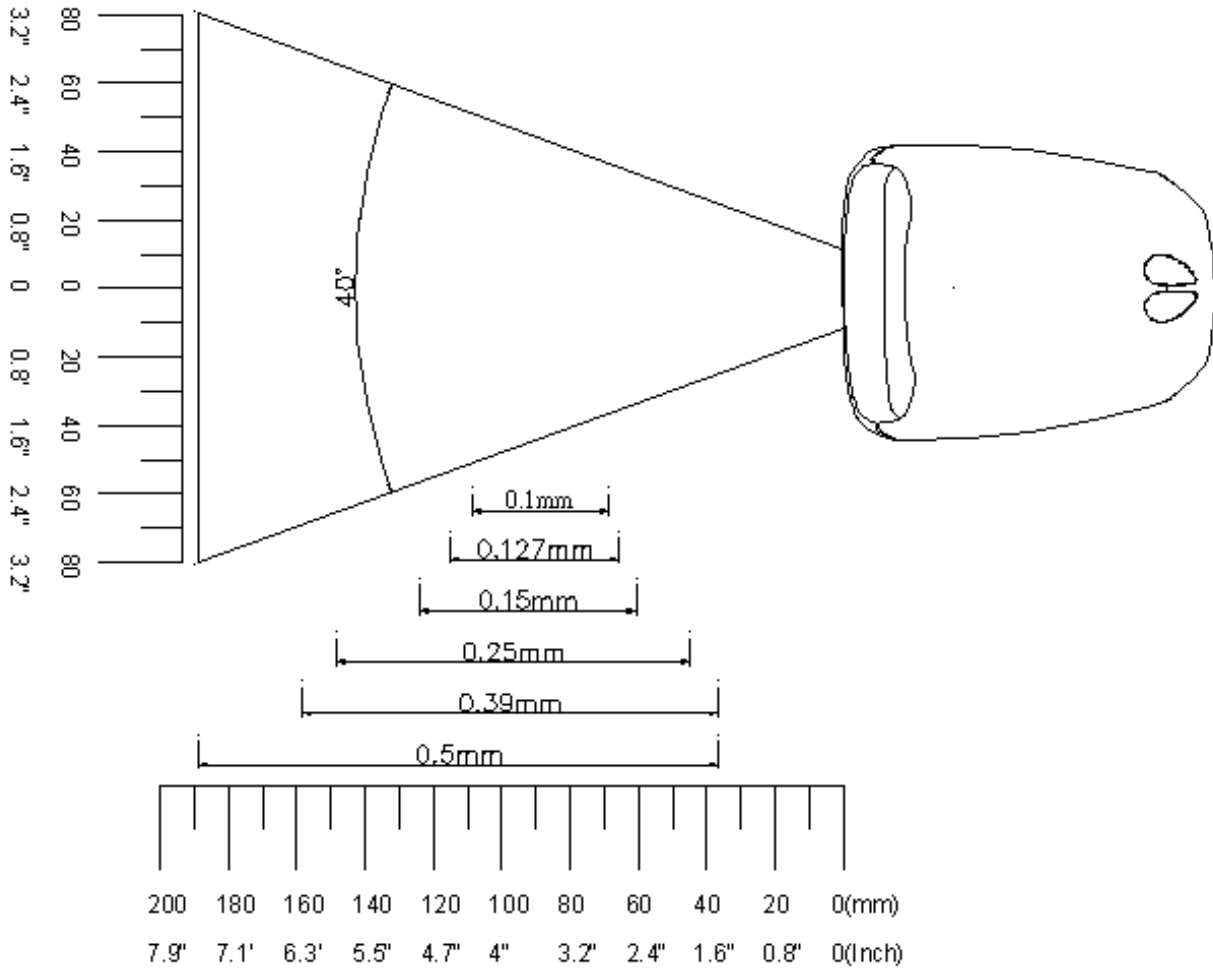

I. Reliability

Life Time

Light Source	20,000 hours
Trigger Switch	1,000,000 times
MTBF(Calculated)	22,000 hours

Thermal Shock

High Temp.	60 °C (140 °F)
Low Temp.	-20 °C (-4 °F)
Cycle time	30 minutes for high temp. , 30 minutes for low temp.
Cycles	24 cycles

Cable Bending Test 25,000 times minimum (30 times/min @ 500g/90°)

Mechanical Shock 40 inch (100 cm) Drop on Concrete Surface



J. Packing

Dimension

Unit	24 cm X 10.9 cm X 8.6 cm
Carton	56.5 cm X 37.5 cm X 27 cm

Weight

Unit	345 g
Carton	7.87 Kg (Q'ty :20 pcs)

Storage

Temperature	-20 °C to 60 °C (-4 °F to 140 °F)
Humidity	20% to 95% (Non-condensing)

Unit :

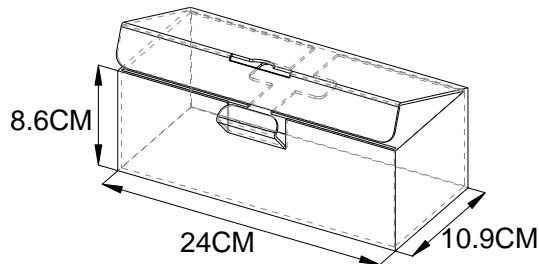

Carton :

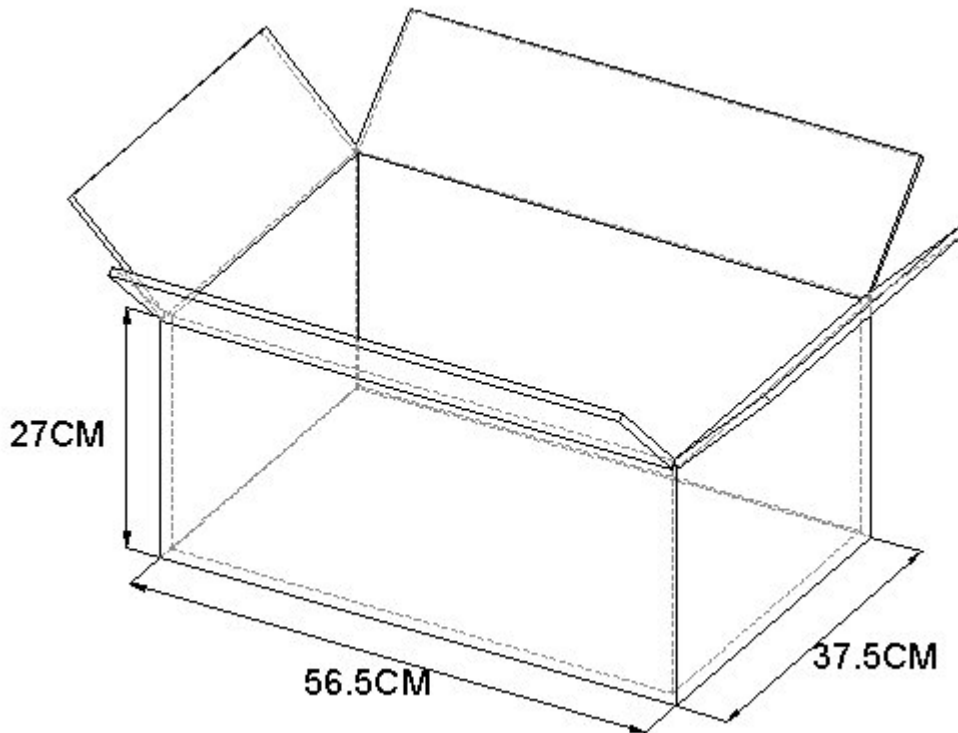

K. Part Number

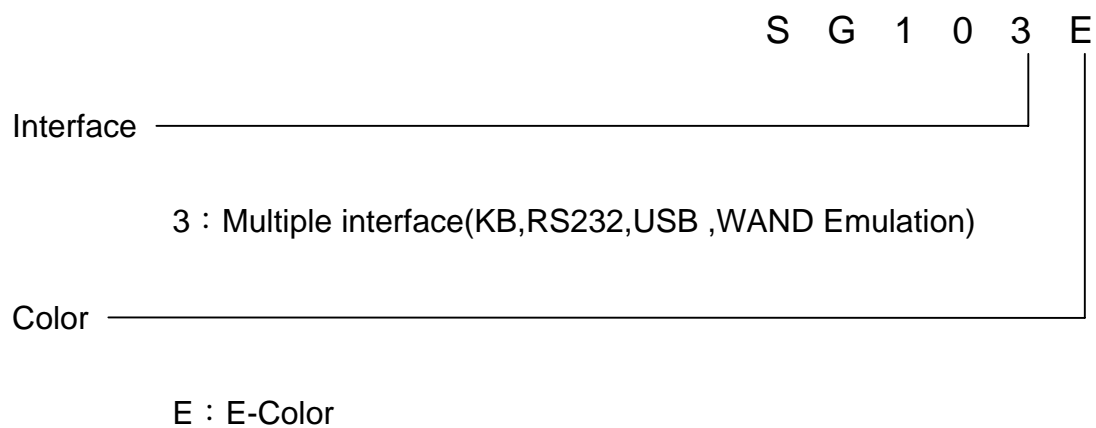

Cable P/N :

Interface	Color	Cable P/N:
KB	E-Color	004SD805/PS2
	Black	004SD805B/PS2
RS232	E-Color	304SD802
	Black	304SD802B
USB	E-Color	304SD808
	Black	304SD808B

